

www.levpano.com

**LEVPAÑO I**®

REF 513000

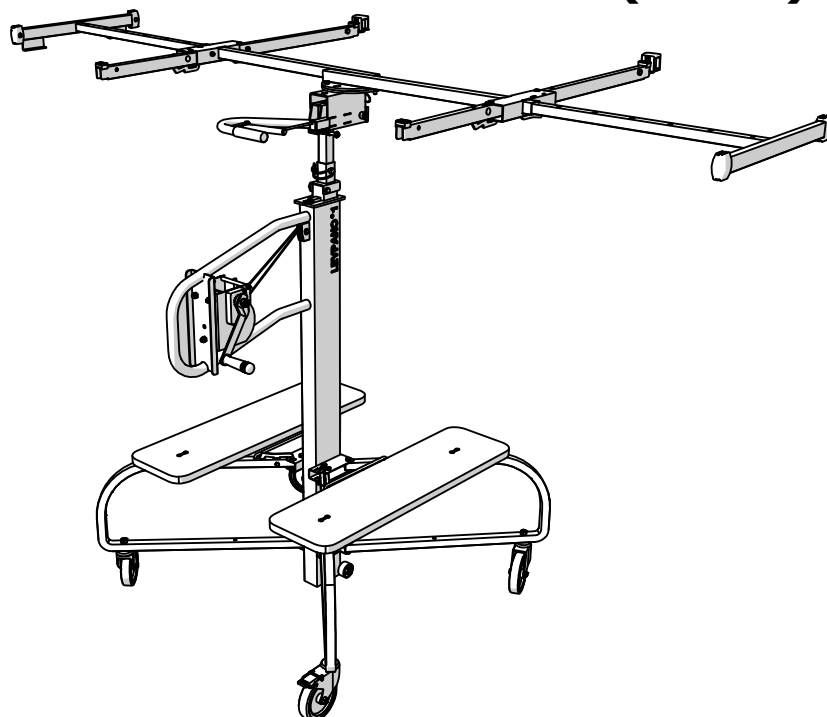

**HSS2046 (B02A)**

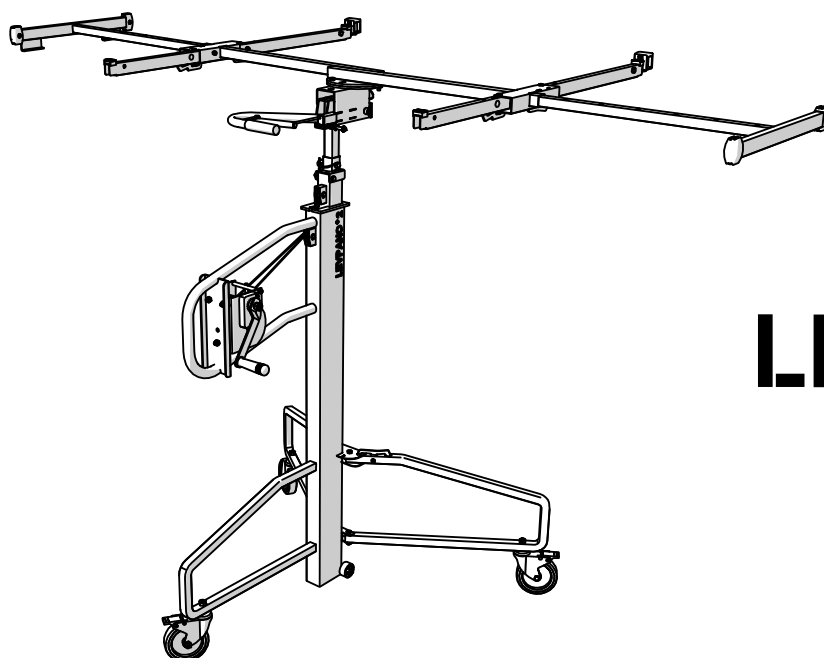

**CE**

**LEVPAÑO II**®

REF 514000

FR NOTICE D'INSTRUCTIONS ET DE MAINTENANCE  
EN INSTRUCTIONS AND MAINTENANCE MANUAL  
DE BEDIENUNGS-UND WARTUNGSANLEITUNG  
NL GEBUIKS-EN ONDERHOUDSAANWIJZING  
IT AVVERTENZE, ED ISTRUZIONI, PER LA MANUTENZIONE  
ES MANUAL DE INSTRUCCIONES Y MANTENIMIENTO  
RO INSTRUCȚIUNI ȘI ÎNTREȚINERE  
HU HASZNÁLATI ÉS KARBANTARTÁSI ÚTMUTATÓ

page 1  
page 4  
Seite 7  
Bladesijde 10  
Pagina 13  
Página 16  
Pagina 19  
Oldal 22



MOB - MONDELIN SAS ZI Le Maroquin F – 42820 AMBIERLE  
NOTICE N° M 00736 révision du 20/11/2019 – Notice originale

VIDEO





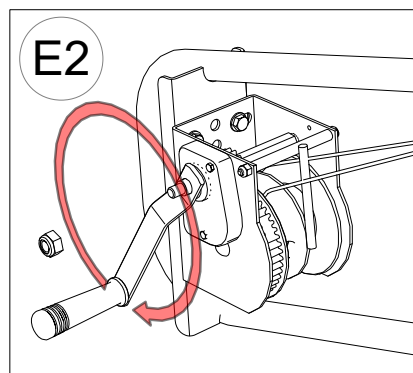
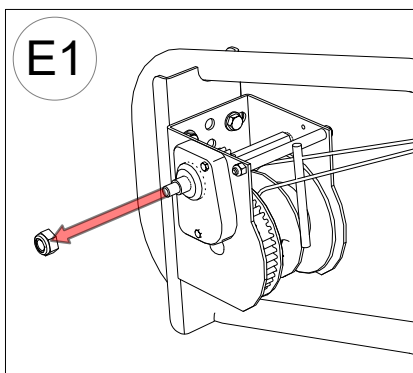
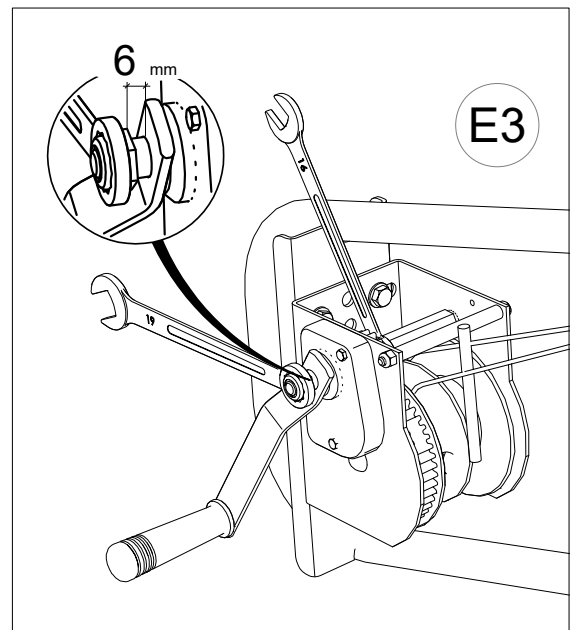
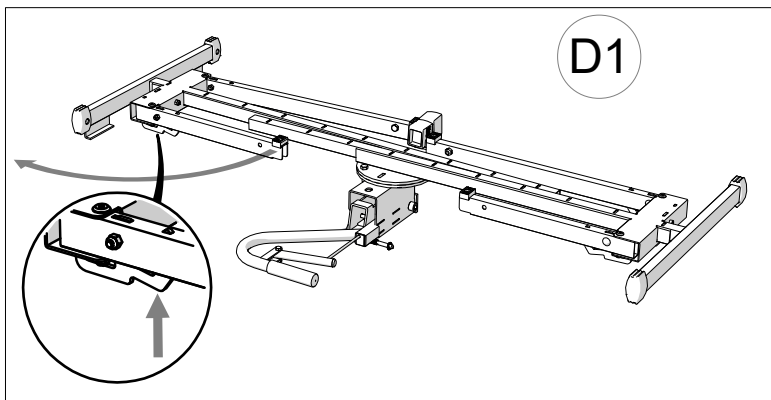
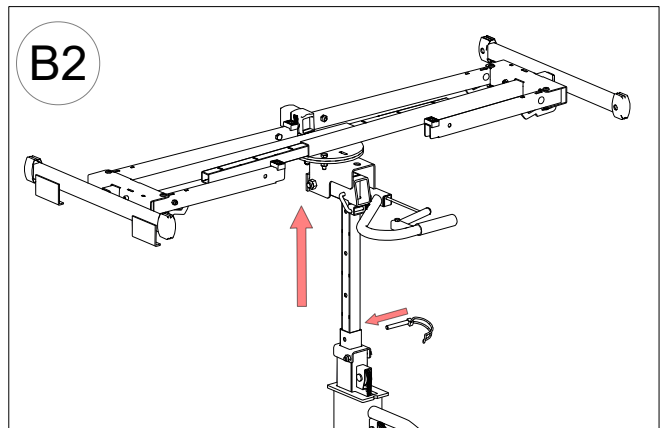
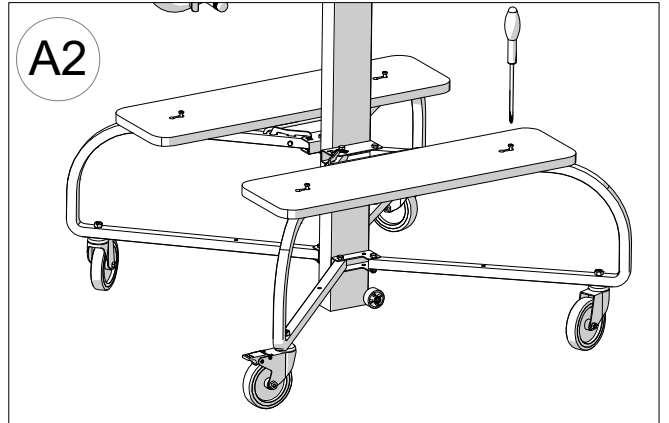
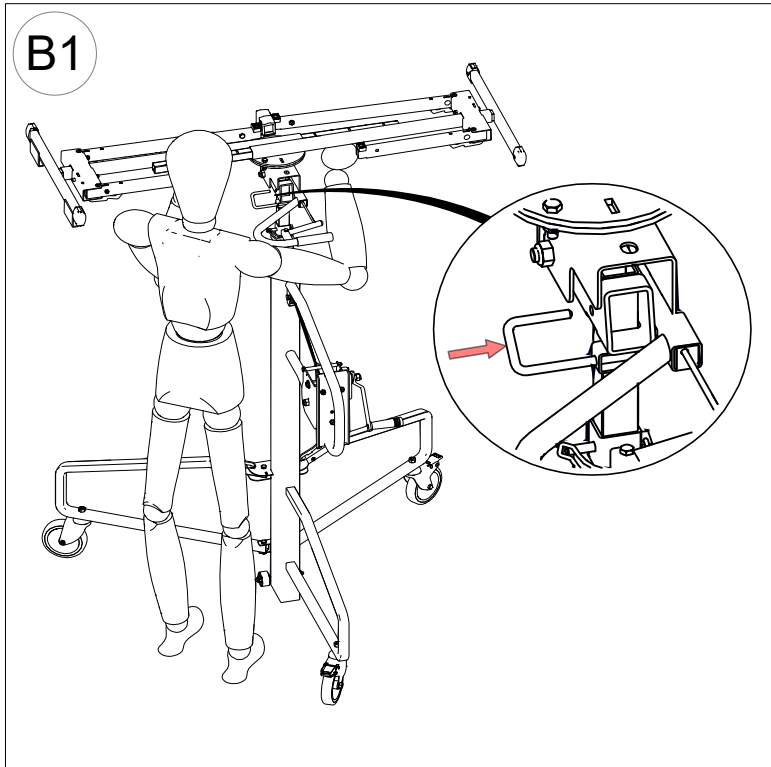
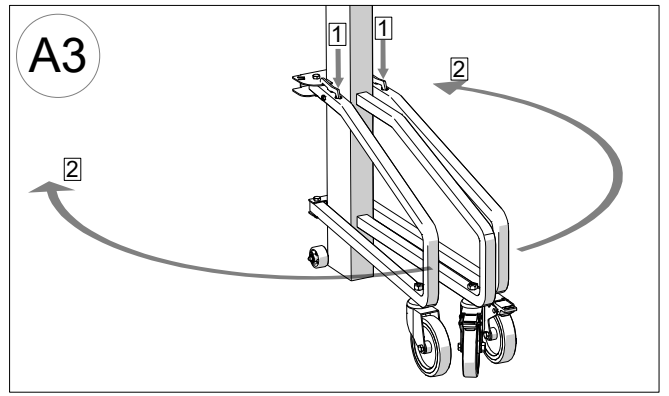
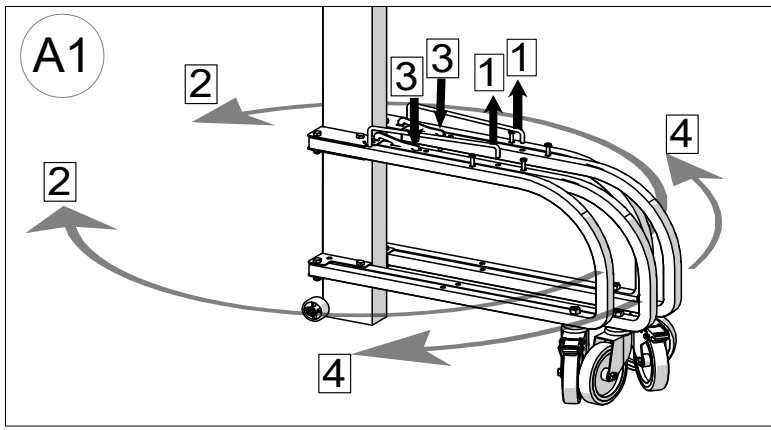

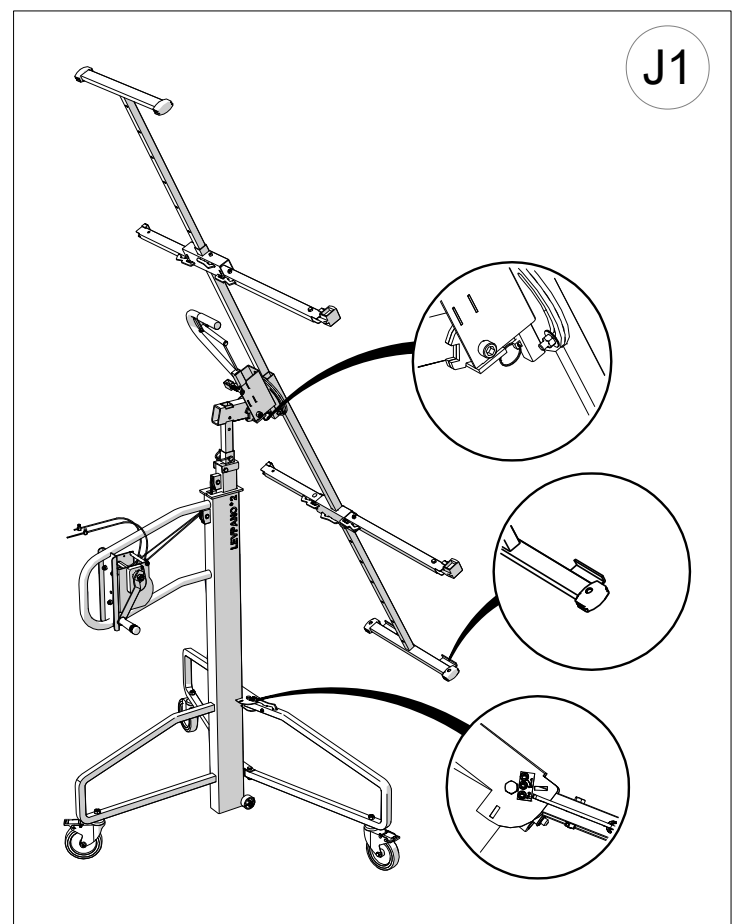
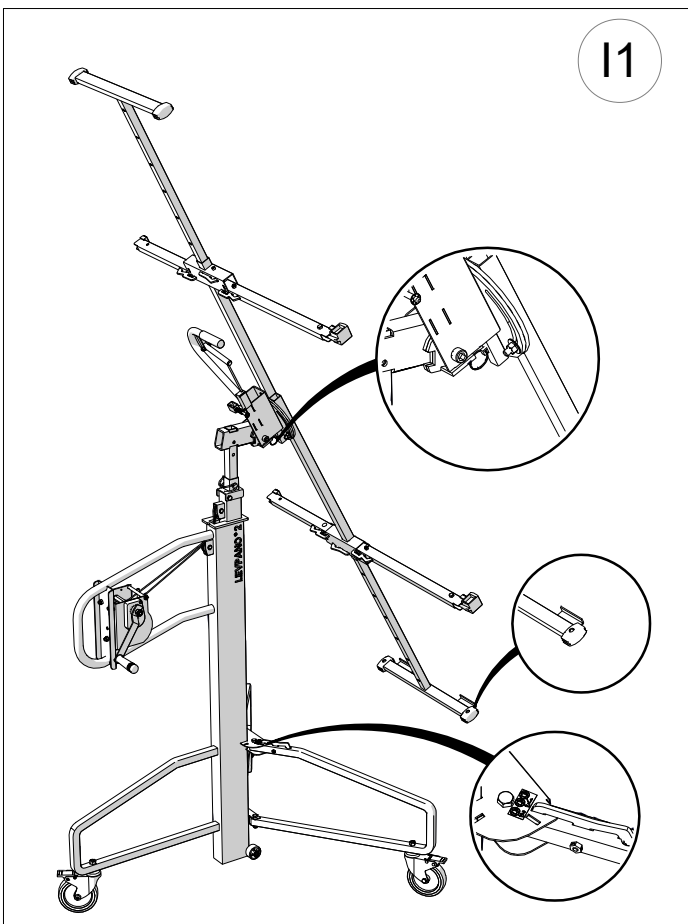
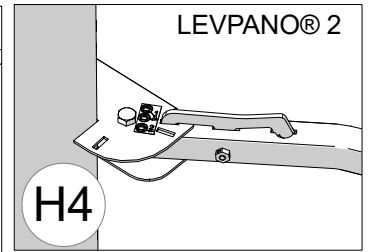
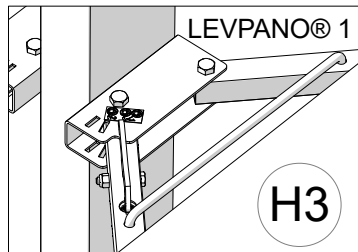
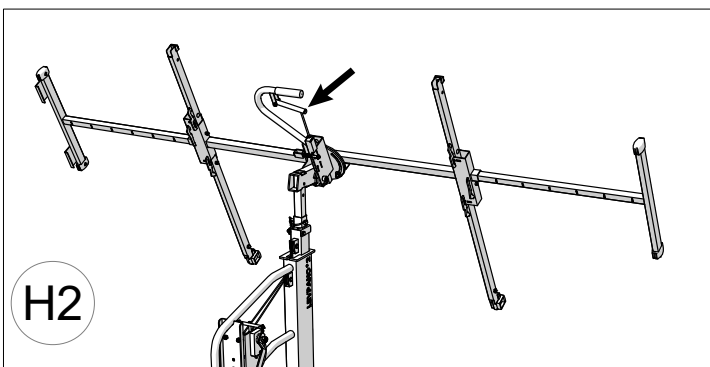
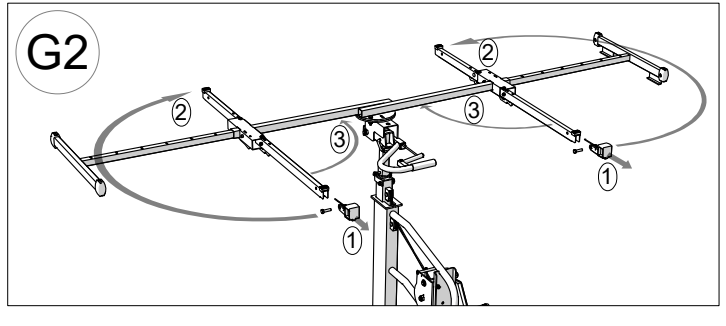
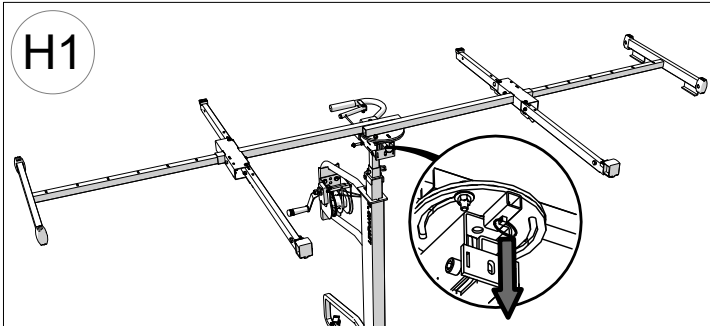
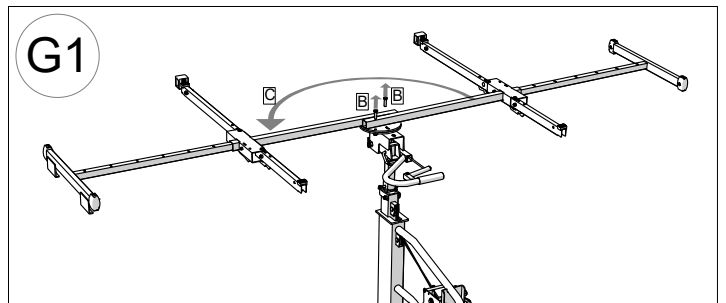
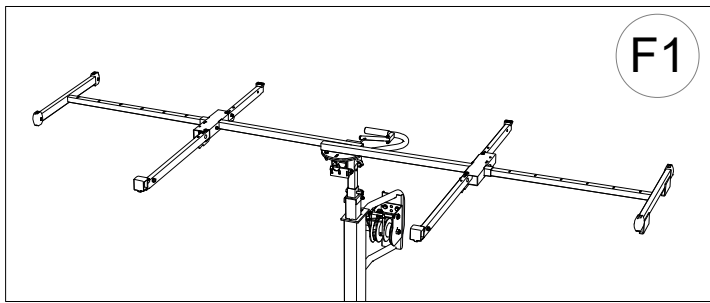

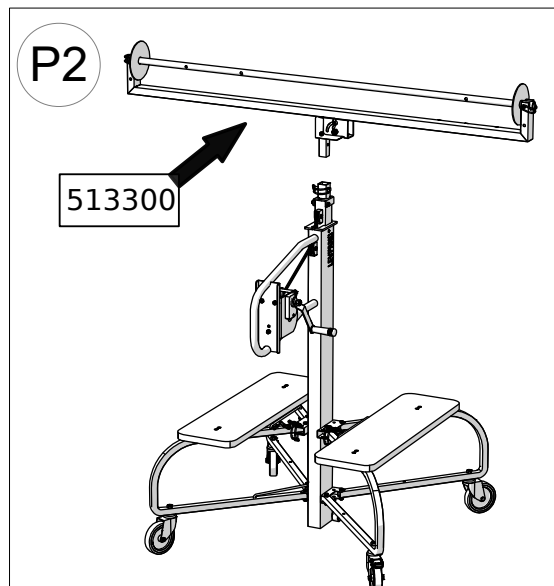
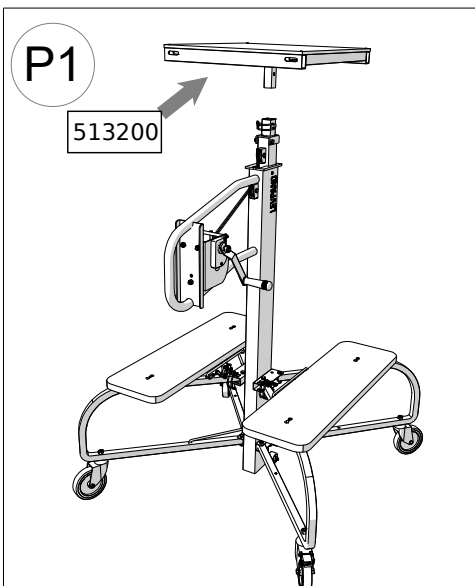
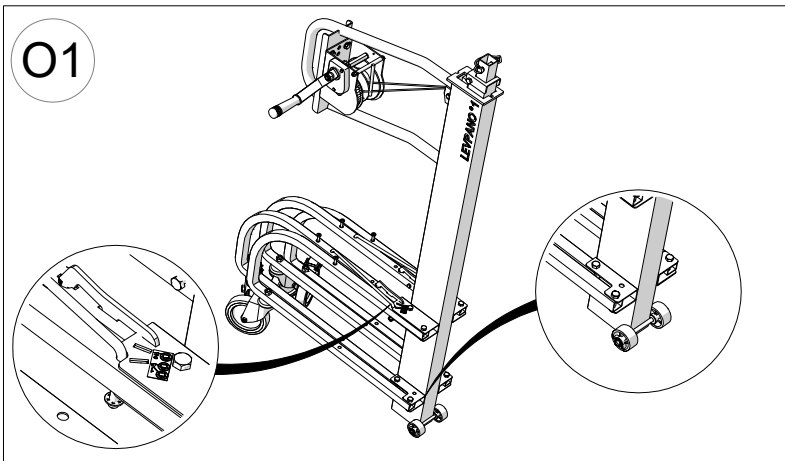
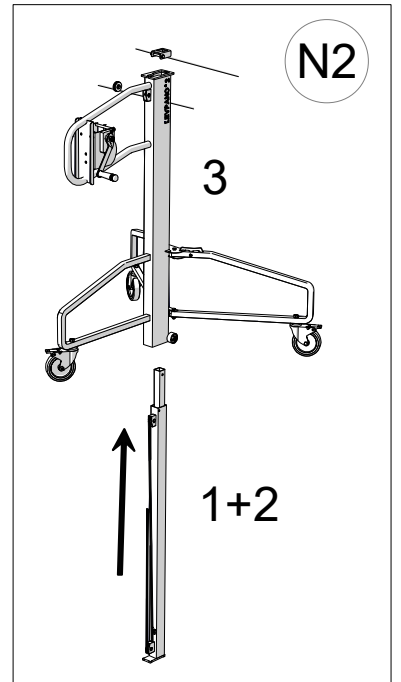
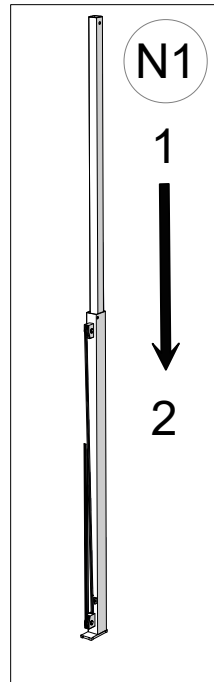
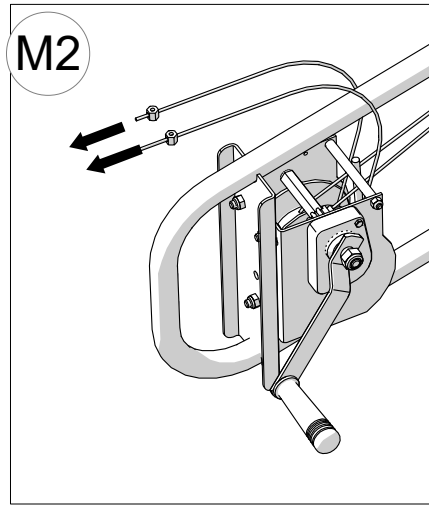
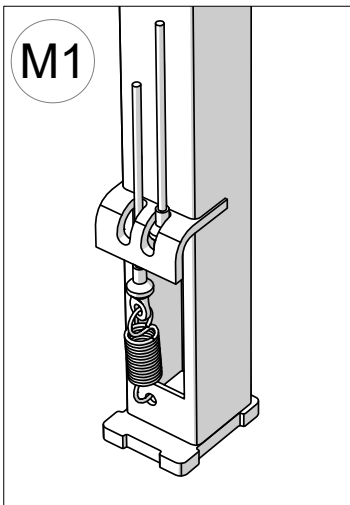
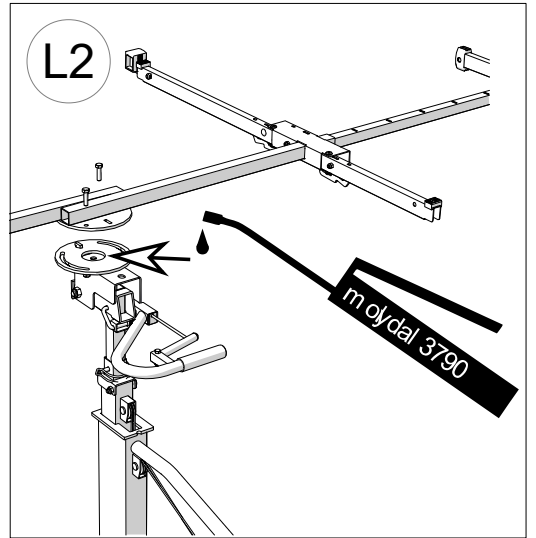
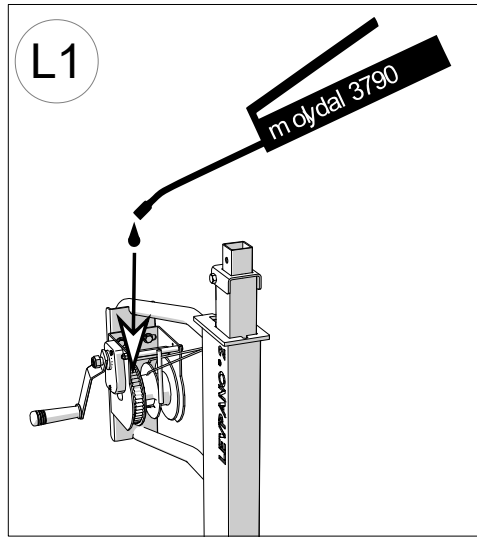
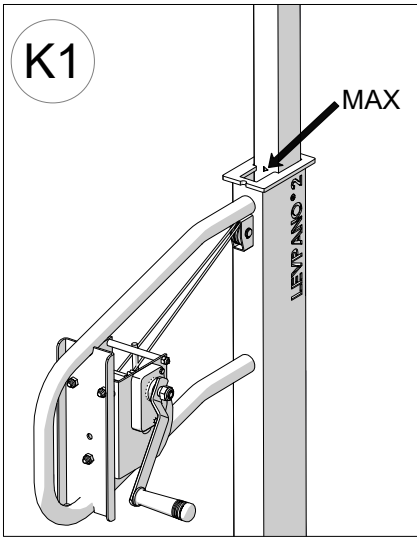

## A. FITTING INSTRUCTIONS AND DIRECTIONS FOR USE



This device has been designed exclusively for **fixing plasterboard panels**. Any other use of this equipment is strictly forbidden and no responsibility can then be assumed by the manufacturer. Make sure that this device is not used in open premises which might be exposed to violent winds. The wheels of a LEVPANO® must be on level ground without any major obstacle. Any modification to the arms, including for an use other than that provided for by the manufacturer, is forbidden.

**This device is a hand-operated lifting device used to fix plasterboard panels.**

**Read the indicator plate on the device carefully.**

## Video

## 1. Fitting the various elements of the Levpano®

LEVPANO® 1 réf 513000

Position the base on the 4 wheels, following the instructions below: **A1**

- 1) Unlock the feet, by raising the hooks
- 2) Open the 2 external feet
- 3) Press the Clip & Go locks
- 4) While keeping the Clip & Go locks pressed, open the 2 internal feet up to position 1-2

Lock the 2 wheels provided with a brake in order to facilitate the putting in place of the parts.

Fit the 2 wooden platforms, inserting respectively their 2 holes onto the screws intended for their fastening. Unscrew then slightly, then move the platforms a little and fix them firmly using the 4 screws **A2**. **NOTE:** the 2 platforms can only be used for fixing on ceiling or under pitches

LEVPANO® 2 réf 514000

Position the base on the 3 wheels, following the instructions below: **A3**

- 1) Press the Clip & Go locks
- 2) While keeping the Clip & Go locks pressed, open the feet up to position 1-2

HEAD AND BEAM LEVPANO® 1&2

Position the head and beam assembly on the extension tube situated at the top part of the small column.

To perform this operation, position yourself to the left of the winch. **B1**

Lock this assembly on the extension tube, using the pin forming one part with the head.

Adjust the head extension tube according to the fixing height required. (See document **C1**)

Unlock the 4 folding arms which equip the beam: **D1**

- 1) Press the Clip & Go lock
- 2) While keeping the Clip & Go lock pressed, deploy the arms
- 3) Repeat these operations for each arm

FITTING THE WINCH'S HANDLE

**NOTE :** For reasons of convenience and safety during transport, the winch's handle (item 1) is supplied dismantled, and the lock nut (item 2) fitted on the pin (item 3).

- 1) Remove the lock nut from the pin **E1**
- 2) Take the handle and screw it completely on the pin (without forcing), so that there is no clearance **E2**
- 3) Keep the winch and the crank handle in this position (Clearance = 0), irrespective of the angular position of the handle.
- 4) Fit the lock nut onto the pin
- 5) Whilst keeping the position of the crank handle in relation to the winch as indicated in **E3**, immobilize the pin using pliers, or with a 16 mm open-end spanner, and lock the lock-nut with a 19 mm open-ended spanner.
- 6) With the assembly correctly fitted, you must have a running clearance between the crank handle and the nut of about 6 mm. **E3**

## 2. Adjustment of the folding arms

Depending on the width of the plasterboard panels to be fitted, adjust the 4 folding arms in the corresponding position.

1.20m wide panels **F1**

Keep the initial adjustment (A), i. e. the 4 arms deployed and the removable stops fitted on the longest arms.

0.90m wide panels

Undo the two nuts situated at the bottom of the swivelling disc in order to remove the screws (B).

Remove the beam, arm and extension assembly. To do so, rotate this assembly half a turn (C) and reposition it.

Fit the two screws back and tighten the nuts moderately in order to keep the play needed by this beam, arm and extension assembly to pivot.

Remove the 2 removable stops and fit them at the end of the other 2 arms. **G2**

Fix the 2 removable stops, using the screws and nuts (D), complying with a play of 1 mm when tightening the nut in order to ensure a proper operation of the removable stops (E).

Unlock the longest 2 arms, using the Clip & Go locks, fold them back, and then lock them in this position.

0.60m wide panels **G1**

Adjust the beam, arm and extension assembly in the same way as for the 0.90m long plasterboards.

## 3. Adjustment before use

Position the extensions by means of the Clip & Go locks, depending on the dimension of the plates and according to the table below:

Adjustment of extensions	Length of the panels to be fitted
3100 mm	3200 mm and fitting under pitches
2900 mm	3000 mm to 3100 mm
2700 mm	2800 mm to 2900 mm
2500 mm	2600 mm to 2700 mm
2300 mm	2400 mm to 2500 mm
2100 mm	2200 mm to 2300 mm
1900 mm	2000 mm to 2100 mm
1700 mm	1800 mm to 1900 mm
1500 mm	1600 mm to 1700 mm
1300 mm	Closing of the extensions

Lock the extensions in the corresponding position, using the Clip & Go locks. Position the panels so that the load is evenly distributed.

## 4. Horizontal fixing (or on ceiling)

For horizontal fixing, the operator must make sure that the beam is indeed in the position shown on the view **H1**. Otherwise, unlock the bottom of the beam in order to pivot it a quarter of a turn and then lock the beam in this new position.

Operate the lever situated on the operating handle in order to tilt the beam. **H2**

Verify that the feet situated at the front of the device are correctly adjusted for horizontal fixing, making sure that the Clip & Go locks are in position 1. **H3 H4**

Now, load the plasterboard onto the arms, with the latter in the tilted position.

Bring the beam and the plasterboard back in the horizontal position, using the operating handle, and raise the columns so as to put the plasterboard in place.

For horizontal fixing (or fixing on ceiling) and after bringing the assembly back in the horizontal position, it is possible to unlock the beam so as to make it possible for the latter to pivot over approx. 90° around its tilting axis.

This tilting of the beam enables the operator to adjust the positioning of the plasterboard at the ceiling.

## 5. Fixing under pitches

To fix boards under pitches, unlock the beam's base so as to pivot it a quarter of a turn and then lock the beam in this new position. **I1**

Operate the lever situated on the operating handle so as to tilt the beam.

Verify that the feet situated at the front of the device are correctly adjusted for fixing under pitches, making sure that the Clip & Go locks are, indeed, in position 2, otherwise adjust the feet.

Turn the arm extension ref. PR0429 (see diagram part) so that the metal stops are placed upwards to receive the plate.

Now, load the plasterboard onto the arms, with the latter in the tilted position.

Raise the columns so as to bring the plasterboard's top in contact with the "paddings" and then continue rotating the winch's handle until the plasterboard is in its final position under the "paddings" and fix the handle.

## 6. Vertical fixing (or on partition)

To fix boards vertically (or on partition), adjust the beam in the same way as for fixing under pitches. **J1**

Operate the lever situated on the operating handle so as to tilt the beam.

Adjust the two feet situated at the front of the device, introducing the Clip & Go locks in position 2.

Rotate the arm extension, ref. PR0429 (see diagram part), so that the metal stops are upwards and can receive the plasterboard.

Now, load the plasterboard onto the arms, with the latter in the tilted position.

After moving the device close to the uprights on which the plasterboard will be positioned, the operator shall operate the lever situated on the operating handle so as to release the lock from its location and thus make it possible for the beam and the plasterboard to tilt into the vertical position for positioning on the uprights. Continue rotating the winch's handle so as to bring the plasterboard's top in contact with the ceiling. Immobilize the LEVPANO® by operating the wheel brakes and then fix the plasterboard on the uprights.

Provide for sufficient space between the bottom of the plasterboard and the floor in order to release the metal stops from the arm after fixing the plasterboard.

### 7. Using the platforms of the LEVPANO® I

As specified in paragraph 1, the platforms supplied with the LEVPANO® I can be used to fit plasterboard panels in order to fix them on ceiling or under pitches. When the platforms are used, they must be firmly fixed to the chassis, using the 4 screws.

## B. SAFETY RULES

### Make sure that :

The wooden platforms are firmly fixed to the chassis (LEVPANO® I réf.513000) if these are used

All the elements are perfectly assembled,

Nothing impairs the proper working of the LEVPANO®,

Before lifting a load :

Make function the LEVPANO® and check the general state of the device.

Make sure that the head locks function properly.

Also make sure that the various Clip & Go locks operate properly.

Make absolutely sure that the cables are correctly wound on the winch's drums, and check their position in the groove of the corresponding pulleys.

Verify that the cables are parallel to the inside of the columns so as to enable the assembly to work properly.

Lock the 2 wheels provided with a brake.

Make sure that the columns are clean

**Do not rotate the winch crank any longer, when the indicator situated at the bottom of the intermediate column appears. K1**

**THE FOLLOWING IS FORBIDDEN : Do not use the LEVPANO® :**

**beyond the maximum use load (75 kg)  
if a cable is broken**

**beyond the maximum fixing height, according to the adjustment chosen for the head tube.**

**Do not remain under the load.**

**When using the LEVPANO®, comply with the work hygiene and safety rules.**

## C. MAINTENANCE OF THE LEVPANO®

### 1. General maintenance

Check the following parts at regular intervals, according to the indications given in the table below:

PARTS	FREQUENCY			TYPE OF VERIFICATION	
	Week	Month	Visual check	Test	Lubrication
The condition of the cables, pulleys and pulley pins,		X	X	X	
The condition of the rubber stops and shoes,	X		X		
The condition of the Clip & Go locks on the arms, extensions and feet	X		X	X	
The condition of the tilting and pivoting locks	X		X	X	
The conditions of the wheels and the operation of the wheel brakes,	X		X	X	
The fixing and clamping devices		X	X		
The cleanness of the columns,	X		X	X	
The condition of the winch and its function (see § 2)	X		X	X	X
The condition of the head and its function (see § 3)		X	X	X	X

And replace if necessary.

Any defective cable must be replaced by a genuine cable.

Characteristics of the cables: diameter 3 mm, composition: 7 x 19 wires, actual breaking load: 5.75 kN

### 2. Maintenance of the winch :

The winch requires regular servicing by a competent department. Regular cleaning makes for a longer service life.

- Never work with a defective cable.
- Keep the pinions, bearings and reel pin well greased. Use a Molydal N°3790 type grease. L1
- Keep the winch in good operating condition. Non-serviced mechanical parts can cause operating problems or even accidents.

### 3. Maintenance of the head :

The head requires cleaning at intervals.

Verify that there is sufficient play to make it possible for the discs to pivot to each other.

Make sure that the two pivoting discs are always correctly greased.

Use grease of the Molydal type, N°3790 L2

## D. PROCEDURE FOR CHANGING THE TWO CABLES

### Material required :

One 8 mm open-ended spanner      One 10 mm open-ended spanner  
Pliers      Circlip pliers  
One end-fitting cable spare kit ref. PR 0012 comprising : 2 universal cables and 1 spring.

#### 1. Removing the safety and traction cables

- a) In the working position, remove the head, beam and arm assembly from the head extension tube after removing the pin situated at the bottom of the head.
- b) Unwind the winch's 2 cables completely (pull on them). The 2 cables are fixed on the winch's reel by means of 2 cable clamps. Remove the 2 cable clamps on the outside of the reel then, using the 8 and 10 mm open-ended spanners, unscrew the 2 cable clamps. The 2 cables are thus released.
- c) Undo the M8 lock nut and remove the M8 x 65 hex. head screw in order to remove the top collar from the intermediate column and to release the frame columns.
- d) Take out the inner column ref. 1 and intermediate column ref. 2 assembly (with the cables). Position this assembly horizontally on 2 trestles (see drawing page 21).
- e) Separate the inner column ref. 1 from the intermediate column ref.2 (see drawing N1).
- f) Remove the worn traction cable from the cable hooking support. Replace the latter with the new cable (see sketch, M1).
- g) Using pliers, move the spring's loop away so as to disengage the spring from the column. Replace the worn safety cable with the new cable, fixing one of the loops of the new spring to the cable's loop. Fix the other loop of the spring to the column (see sketch, M2).

#### 2. Refitting the cables

- a) Before refitting the columns in the frame, item 3 N1 N2, remove the pulleys from the frame, removing the circlip situated at the end of the pin, so as to make insertion of the cables easier.
- b) Slide the inner column with the cables into the intermediate column, item 2, then insert the safety and traction cables onto the upper pulleys, then onto the lower pulleys of the intermediate column, see drawing, N1 N2
- c) Refit the columns assembly in the LEVPANO®, taking care not to trap the cables. Insert the 2 cables into the housing of the 2 pulleys removed from the frame, item 3.
- d) Refit the pulleys and their pin, making sure that the cables do not overlap, then fit the circlip.
- e) Refit the intermediate column's top collar and fix it with the screw and the nut.
- f) Refit the 2 cables on the winch's reels, taking care not to cross them, manually pull the 2 cables and fix the cable clamps on their respective cable, making sure they are at the same level to each other, as show on sketch M2. Using the crank handle, wind the cables onto the winch.
- g) Refit the head, beam and arm assembly onto the head extension tube and immobilize the whole by means of the pin situated at the bottom of the head, then perform a few up and down movement tests (with no load).

**RECOMMENDATIONS :**

- Do not overlap the cables when refitting.
- Take care to make the position of each part visible before removing it so as to limit the risks or errors.

**E. TRANSPORTING THE LEVPANO®**

**1. Transport from a building site to the next one**

In order to make transport from a building site to the next one easier, the LEVPANO® is broken down into 2 or 3 elements depending on the model:

- The frame equipped with 2 rollers at the bottom of the column makes transport easier **P1**
- The head and beam assembly
- The working platforms (LEVPANO® I)

**Weight of the various elements :**

	LEVPANO® I	LEVPANO® II
Frame (equipped with 2 transport rollers)	30.9 Kg	28.2 Kg
Head and beam	14.9 Kg	14.9 Kg
Working platforms (LEVPANO® I)	6 kg	

The shape given to the transport handle on which the winch is fixed enables also the operator to carry the frame assembly on the shoulder.

**2. Transport on the building site**

Depending on the model, the LEVPANO® is equipped with three or four 125 mm dia. wheels, two of them are equipped with brakes.

The transport handle on which the winch is fixed enables the operator to guide the LEVPANO®.

**F. TROUBLESHOOTING GUIDE**

If there is apparently a fault on the LEVPANO®, go through the following points before asking for it to be repaired, taking all necessary safety precautions (wear a helmet, goggles and gloves).

If the device is locked in the raised position, make sure that the plasterboard panel is fixed at the ceiling or secure this by means of supports, before attempting to unlock it.

DIFFICULTY	POSSIBLE CAUSE	CORRECTION
Device locked in the raised position	- Brake locked	Undo the crank handle and put it back in contact
	- Cables stuck and/or damaged	Check the passage of the cables and their condition
	- Columns locked	Check the cleanness of the columns
Comes down freely without brake	- Excess winch grease	Degrease the lock washer and the support
	- Tightening of the brake	Put the crank handle and the lock washer in contact
	- Lock washer inoperative	Check the condition of the washer
Goes up with difficulty	- Presence of foreign matter	Clean the device
	- A lock remains blocked	Clean the locks
The device does not lock in one of its adjustment positions	- A lock remains blocked	Clean the locks
	- The beam's pivoting discs are blocked	Loosen the pivoting discs, grease the sides in contact and then tighten the discs back, complying with an operating play

**NOTE :**

If the problem persists, contact the After-Sales Department.

For any spare parts order, refer to the exploded view, page 1 for the LEVPANO® I or page 3 for the LEVPANO® II.

**G. WARRANTY**

This device is guaranteed against manufacturing defects for 5 years from its date of purchase mentioned on the retailer's invoice.

Claims under this warranty can only be taken into account if the instructions given in the user's manual and more particularly in paragraphs A, B, C and D are strictly complied with.

Deteriorations caused by normal wear (wheels, pulleys, cables, winch, arm shoes with spring, arm pads), abnormal use, incorrect servicing/maintenance or overload, are not covered by the warranty.

Failure resulting from a use other than that for which the LEVPANO® has been designed, i.e. the fixing of horizontal plasterboard at the ceiling, under pitches or vertically on partitions, cannot be repaired under the warranty.

**H. ACCESSORIES**

The LEVPANO® can be equipped with the following accessories:

Steam protective unwinder ref. 513300 **P1**

Support platform ref. 513200 **P2**

**I. END OF LIFE OF THE PRODUCTS**

The metallic parts must be separated from the plastic components in order to ensure recycling in accordance with the regulations in force.